



KIS100  
Power Gate Operator  
Installation Manual

**Table of Contents**

Introduction	page 1
Technical Specifications	page 2
Installation Mechanical	page 3
Installation Electrical	page 5
Electrical Schematic	page 6
Troubleshooting	page 7
Emergency Power Connections	page 8
Maintenance and Servicing	page 9

**PATENT PENDING**



Porta Inc.  
250 Hamilton Rd.  
Arlington Heights, IL 60005

Phone: (847) 593-4900  
Fax: (847) 593-1394  
website: [emiporta.com](http://emiporta.com)

## Introduction

The KIS100 gate operator is a proven product that provides a user friendly, dependable and cost effective means of automating accordion gates used in residential and LULA elevators. It has passed an accelerated life test of 25 years of normal residential use (100,000 cycles).

This product conforms to UL508A, ASME A17.1A, ASME A17.5, CSA-B44-94, and CSA-C22.22, No. 14-M91.

### Features & Benefits

- **Two Speed bi-directional gate operation**

- **Selectable Auto-Close feature**

Will automatically close the gate when the open signal is removed

- **Variety of Control Signalization**

The KIS100 can accommodate a variety of control voltages or dry contact signals.

- **Emergency Power Input**

In the event that the 110VAC power is interrupted, 24VDC may then be applied to operate the unit.

- **GAL type G gate switch (optional)**

Mounts within the KIS100 chassis

- **Micro-switch slow downs and limits**

Provide a simple and accurate means of decelerating and stopping the gate

- **Magnetic coupling of gate to operator**

Provides a simple and positive means of preventing damage or injury in the case of an obstruction. If the resistance to gate closure exceeds the magnetic coupler, the gate dis-engages and becomes a manual gate. There is nothing to get out of adjustment or reset. This coupling system also allows for moderate mis-alignment of operator and gate.

- **14" gate arm**

Reduces bottom hinge lag

- **Quiet Operation**

A precision ground lead screw drive system provides virtually silent operation.

- **Retrofit existing installations**

The footprint of the KIS100 is the same as the standard Accordion gate

- **PWM motor drive**

Provides quiet operation, longer motor life and reduced power consumption.



### ATTENTION!

**WARNING:** The installation of this device should only be performed by a professional elevator technician that has a full understanding of this device's operation and function.

Note: If there is any doubt regarding the installation procedures, please call the factory for assistance. We are available M-F 8:00 am to 5:00 pm Central Time.

**WARNING:** Failure to comply with all instructions and "WARNING"(s) can result in a safety system compromise. This, in turn, can result in serious injury or death.

### PATENT PENDING



Porta Inc.  
250 Hamilton Rd.  
Arlington Heights, IL 60005

Phone: (847) 593-4900  
Fax: (847) 593-1394  
website: emiporta.com

## Technical Specifications

Input Power	120VAC
Motor	90VDC
Motor Drive	1A(P.W.M.)
High Speed (nom.)	107sec.
High Speed Adj.	0-120%
Low Speed Adj.	0-80%
Drive Belt	0-Ring (343)
Control Interface Options	Dry Contact
	120VAC
	12/24 VDC
Gate Switch	GAL type G

### Dimensional Data

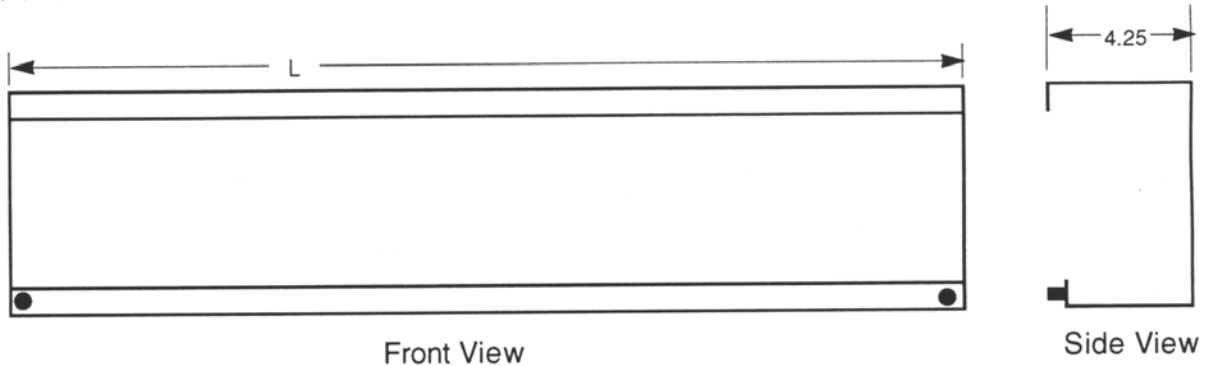

Gate Travel	"L"
29 Inches	36 1/2"
32 Inches	39 1/2"
36 Inches	43 1/2"
42 Inches	49 1/2"

**PATENT PENDING**



Porta Inc.  
 250 Hamilton Rd.  
 Arlington Heights, IL 60005

Phone: (847) 593-4900  
 Fax: (847) 593-1394  
 website: [emiporta.com](http://emiporta.com)

**INSTALLATION - MECHANICAL**

1. Unpack the unit, remove the cover, and check for any physical damage before proceeding.
  2. Check to see that you have the correct hand unit. The operator is designed so the motor is on the stack side of the gate. The operator can be made to work on the opposite hand, but on most jobs it will require a large amount of overhang. The chassis is symmetrical; if necessary you can covert hand in the field, however this will VOID THE WARRANTY.
  3. Operate the gate manually. The door must operate smoothly without any binding. Correct any problems with the gate before proceeding.
  4. Mark a line on the car top corresponding to the centerline or the front edge of the gate track.
  5. If the distance from the gate track centerline to the edge of the car top is more than 1 -1/8", there are two options: Shim out connecting arm (maximum recommended distance is 1/2"), or cut back the edge of the car top. If you need to cut back the car top, do so now - cut so there is 1-1/8" from the gate track centerline to the edge.
- 6. OFFSET GATE APPLICATION**
- For an offset gate, refer to Figure 1b. If the distance from the gate track centerline to the edge of the car top is more than 15/16", cut back the edge of the car top. As illustrated in Figure 1b, the gate track centerline to the car top edge should not exceed 15/16".
7. Place the operator on the cartop. Set the operator so the front edge is 1-1/8" (max) from the centerline or 9/16" (max) from the front edge of the gate track toward the inside of the car, and so the lead end is 3/4" past the gate strike. See Fig 1.

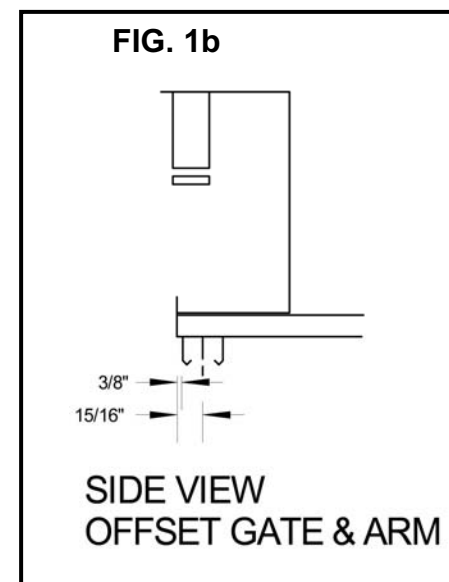
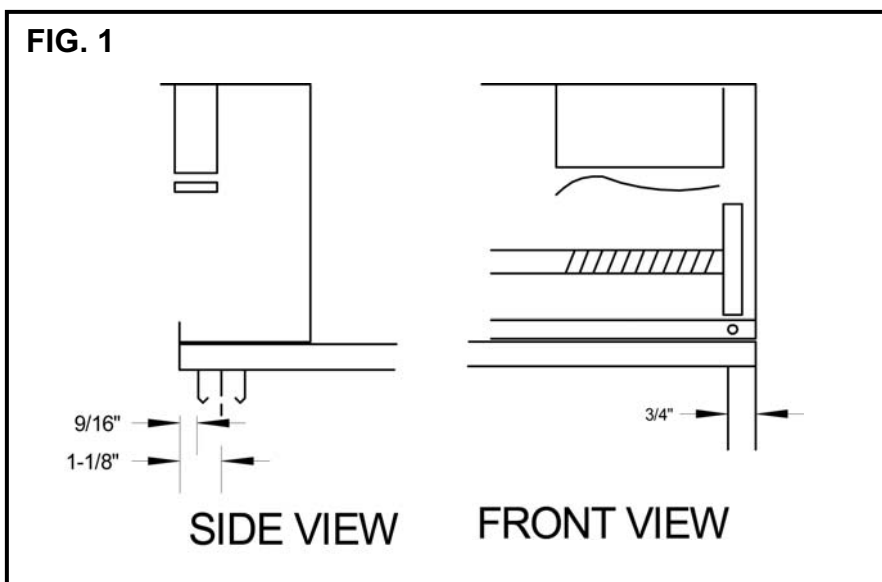

Porta Inc.  
250 Hamilton Rd.  
Arlington Heights, IL 60005

Phone: (847) 593-4900  
Fax: (847) 593-1394  
website: emiporta.com

## INSTALLATION - MECHANICAL (CON'T)

7. Pull the gate to its fully closed position. Check that the drive nut is about 1/2" away from the closed side pillow block; manually rotate the lead screw if necessary (it will be easier to rotate with the drive o-ring removed). Place the gate arm magnet on the magnet flag; the middle of the magnet should be in the middle of the flag. Check that the gate switch is closed, but still has about 1/4" of follow-up. See Fig 2.

8. The gate arm should line up with the gate lead post. If not, minor adjustments can be made by simply moving the gate arm magnet around on the flag. Large adjustments will require repositioning of the operator.

9. With the operator and gate arm in position, mark through the mounting holes for drilling the car top and the gate lead post.

10. Move the operator so you can drill 1/8" pilot holes in the cartop and 1/4" through holes in the gate lead post. **BE CAREFUL NOT TO DRILL THROUGH THE CAR TOP IF THE HOLES WOULD BE VISIBLE.**

11. Attach the operator to cartop. #12 x 3/4 screws are provided for wood cartops. Attach the gate arm with 1/4" -20 x 1 1/4" carriage bolts and acorn nuts. See Fig. 3

12. Manually rotate the lead screw to open the gate about 1/2" from its fully closed position. Adjust the closed limit so that it "clicks" when the gate is about 1/4" from being fully closed; check by manually rotating lead screw.

13. Adjust the close slow down limit so that it is about 2" center-to-center from the closed limit.

14. Manually rotate the lead screw to about 1/2" from its fully open position. Adjust the open limit so that it "clicks" when the gate is about 1/4" from being fully open; check by manually rotating lead screw.

**NOTE: LEAD SCREW ASSEMBLY IS SELF-LUBRICATING. LUBRICATION IS NOT RECOMMENDED.**

**NOTE: IF NEEDED, PETROLEUM JELLY CAN BE USED TO LUBRICATE THE GUIDE RAIL.**

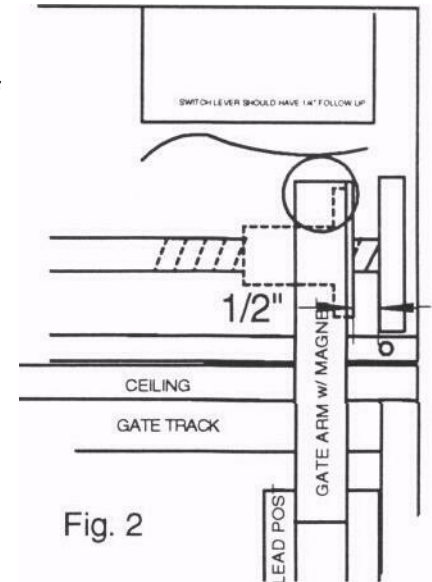

Fig. 2

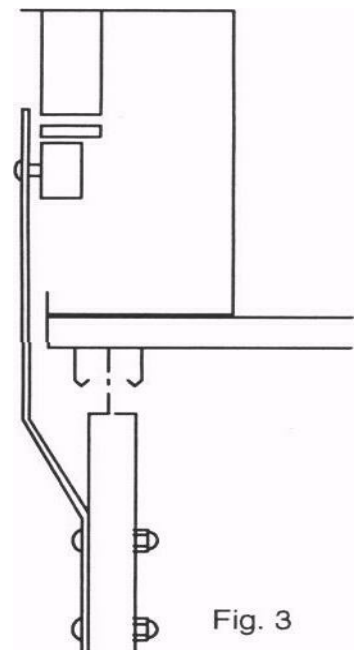

Fig. 3

**Patent Pending**



Porta Inc.  
250 Hamilton Rd.  
Arlington Heights, IL 60005

Phone: (847) 593-4900  
Fax: (847) 593-1394  
website: [emiporta.com](http://emiporta.com)

# INSTALLATION - ELECTRICAL

1. The KIS100 is field wired including the gate switch if so equipped. Run field wires from operator through conduit or greenfield. 2-1/2" knockouts are provided in the chassis for an appropriate fitting.
2. Ground the chassis per code.
3. Verify 120VAC power before connecting the operator.
4. Verify the type and voltage of control signal being used, refer to the Field Connection Diagrams.
5. There are 5 jumpers on the board:
  - SP1: Auto close; with this jumper installed the operator will automatically close when there is no signal to open. Remove if controller provides an independent close signal, or for testing and adjusting.
  - SP2-SP5: Are used to select the control signalization. Refer to the Field Connections Diagrams below for the various configurations.
6. To test unit, set speed pots in the middle of their range. Then use on board toggle switch to open and close the operator. Adjust the speed control and limit switches as necessary.
7. Connect wiring from elevator controller to interface board. Reinstall SP1 if using only an open signal from the controller.
8. Test the unit for automatic operation and replace cover.

## Field Connection Diagrams

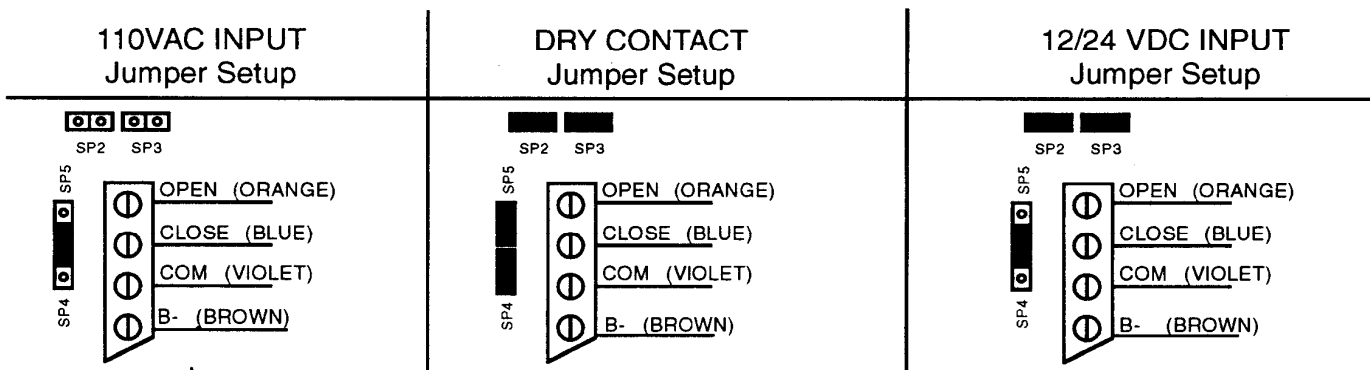

Patent Pending



Porta Inc.  
250 Hamilton Rd.  
Arlington Heights, IL

Phone: (847) 593-4900  
Fax: (847) 593-1394  
website: emiporta.com

## Electrical Schematic

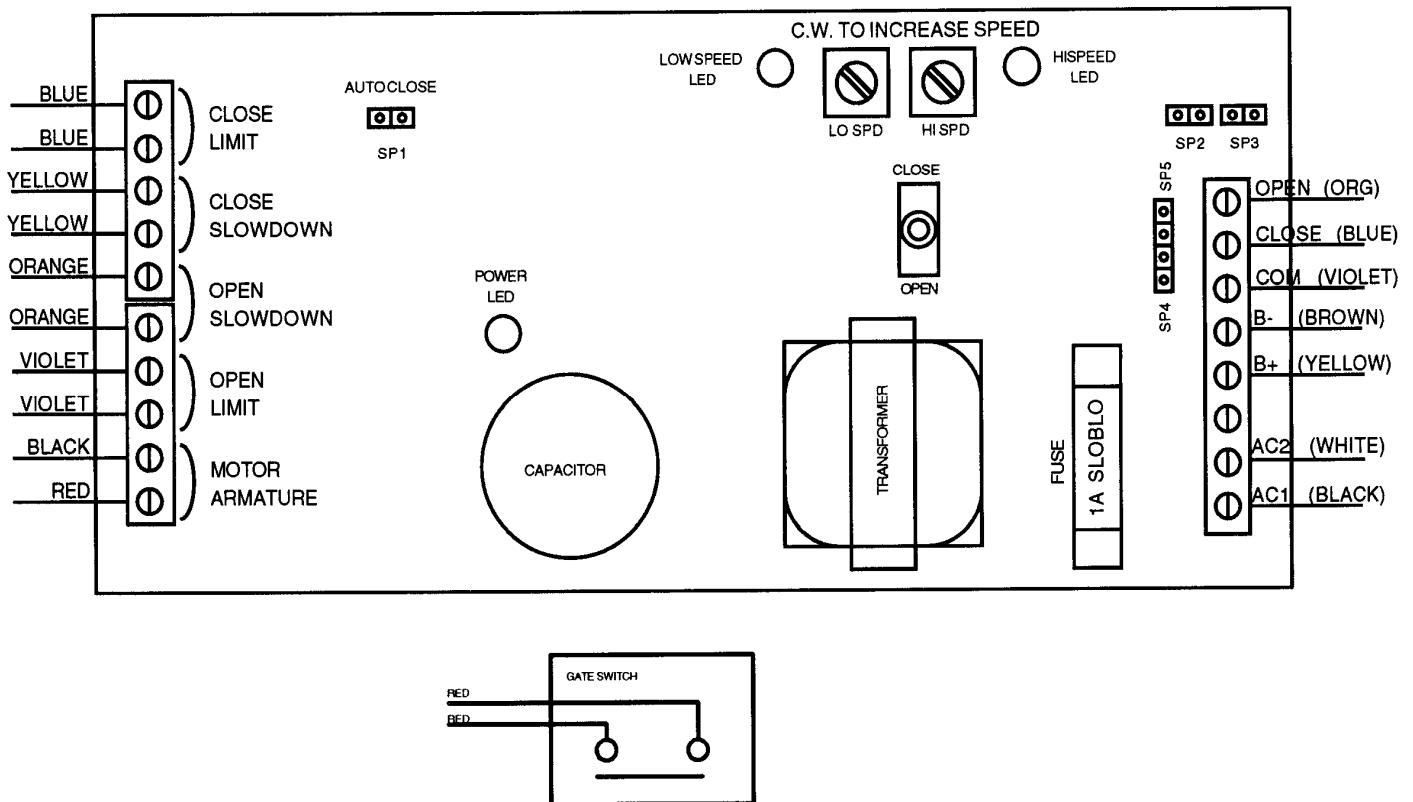

- AUTO CLOSE: Installing jumper SP1 enables this feature.
- Terminals "B+" and "B-" are the 24VDC Emergency Power Inputs.

Do not operate at any higher voltage.

**WARNING: 110VAC** Line voltage and 24VDC Emergency Power must not be present at the same time. **If they are, BOARD DAMAGE WILL OCCUR.**

- Jumpers SP2 thru SP5 are used to select the control signalization.
- Factory jumper setup is for Dry Contact signalization and Auto Close enabled.

**Patent Pending**



Porta Inc.  
250 Hamilton Rd.  
Arlington Heights, IL 60005

Phone: (847) 593-4900  
Fax: (847) 593-1394  
website: emiporta.com

## TROUBLESHOOTING

Problem	Possible Cause	Corrective Action
No Function	No power	Verify 120VAC between "AC1" & "AC2"
	Fuse	Check Fuse "F1"
	Controller Signal	Check operation with test switch
	Faulty Limit	Verify that limits are closed when not actuated
No High Speed	Faulty Slow down	Verify that slow downs are open when not actuated
No low speed	Slow down not actuating	Verify that the cam engages the slow down
	Faulty Slow down	Verify that slow downs have continuity when actuated
Motor turns but no gate movement	Loose Pulleys	Verify that the drive and driven pulley's are tight on their shafts
	O-Ring	Check for loose or missing o-ring
	Gate	Check gate for excessive bind
Reverse operation	Board wiring or controller wiring	Check operation with test switch
		DOWN is open. Swap M+ & M- if necessary
Excessive breakaway force	Step 1	Put small washers on the magnets opposite the flag. If force is still excessive, go to step 2 Remove a magnet. If force is still excessive, put small washers on the remaining magnet opposite the flag.
	Step 2	
Board is powered but motor does not engage	Unit has stalled out	Step 1: Shut off power supply to unit. Step 2: Identify and remove the cause of the stall. Step 3: Power unit back up.

**ATTENTION!**

If the resistance to gate closure exceeds the magnetic coupler, the gate dis-engages from the operator and becomes a **MANUAL GATE**. Advise the user that they must do one of the following:

- Close the door manually to run the elevator
- Cycle the door to re-engage the magnetic coupler.



**PATENT PENDING**



Porta Inc.  
250 Hamilton Rd..  
Arlington Height, IL 60010

Phone: (847) 593-4900  
Fax: (847) 593-1394  
website: emiporta.com



## Emergency Power Connections

### General information:

The KIS100 has the ability to operate at 24VDC in the event 110VAC power is lost. The unit will operate at a reduced speed when powered by 24VDC. Terminals B+ and B- are the battery inputs.

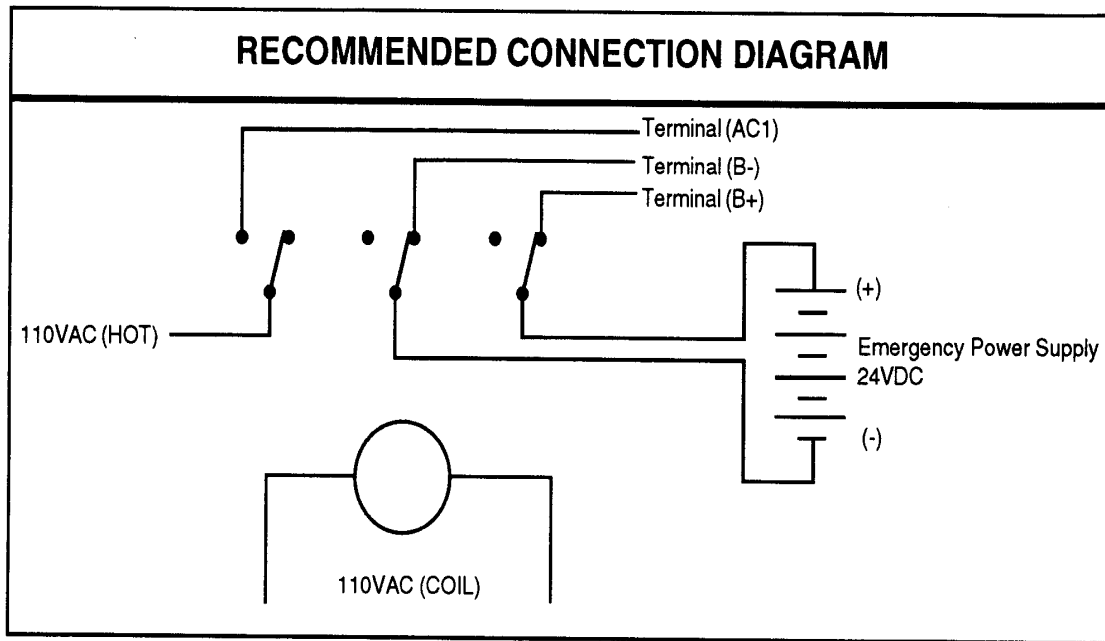

Recommended Relay: Omron LY3 or equivalent

**NOTE:** It is vital that B+ and B- are not connected to the battery when 110VAC is present on the board.

**PATENT PENDING**



Porta Inc.  
250 Hamilton Rd.  
Arlington Heights, IL 60005

Phone: (847) 593-4900  
Fax: (847) 593-1394  
website: [emiporta.com](http://emiporta.com)

## MAINTENANCE AND SERVICING

No servicing is required, but regular inspection of the following is necessary to ensure trouble-free, long-term operation:

1. Ensure the following components are securely mounted:
  - a. Operator chassis to the car top
  - b. Gate arm to gate leadpost
  - c. Magnet assembly to the gate arm
  - d. Magnet strike to the limit switch cam
  - e. Motor, gate switch, PCB and bearing blocks to chassis
2. Check all wire connections and voltage.
3. The gate should cycle through each direction smoothly and should not rattle during operation.
4. Check for dirt or debris buildup on lead screw. Regular cleaning with a liquid degreaser is recommended.
5. Check for proper cam actuation of all four(4) limit switches.
6. Check for proper cam actuation of gate switch.

### **\*\*\*WARNING\*\*\***

All inspections, maintenance, repairs and replacements should be performed by elevator personnel only.



Porta Inc.  
250 Hamilton Rd.  
Arlington Heights, IL 60005

Phone: (847) 593-4900  
Fax: (847) 593-1394  
website: [emiporta.com](http://emiporta.com)