

SELECTOR2 & MOUNTING KIT INSTALLATION MANUAL

4M2 & 6M2 Controllers

PRODUCT DESCRIPTION

Our landing system is designed to interface directly with the 4M2XX and 6M2XX series controllers. The system incorporates bi-polar hall effect sensors with relay outputs.

The selector head is very compact with a footprint of approximately 1 1/2" D x 3" W x 18" L. The 2" steel tape will accommodate 3 lanes.

TAPE INSTALLATION

1. Locate an area as close to a rail as possible that can accommodate the footprint of the unit for the entire length of the hatch.
2. Mount the top clamp retainer so the center of the tube corresponds to where you want the center of the tape to be located. Mount it high enough so the selector head will not hit the top clamp at the furthest extent of up overtravel.
3. Mount the bottom clamp retainer so the center of the tube is plumb with the top retainer tube. Mount it low enough so the selector head will not hit the bottom clamp at the furthest extent of down overtravel.
4. Drill a 3/8" clearance hole in the center of the tape about 2" from the end. Install the top clamp on this end of the tape with 3 - 3/8" bolts. There will be about 1" of extra tape; bend it slightly to clear the threaded rod.
5. Install the top clamp into the top clamp retainer tube with a washer and two hex nuts as shown in FIG. 1A. For now, have the hex nuts at the end of the threaded rod. Carefully unroll the tape and let it hang.

Note: You can save some time by sliding the selector head up the tape and tying it off at the top at this point. The end with the 15-pin connector goes up.

6. Install the bottom clamp into the bottom clamp retainer tube with washers, spring and hex nuts as shown in FIG. 1B. For now, have the hex nuts about 1" from the end of the threaded rod. Put a wedge of scrap material between the clamp and the clamp retainer to compress the spring about 1/2".
7. Pull the tape tight. Mark the tape to correspond to the center hole of the clamp, and drill a 3/8" clearance hole. Cut the tape at least 2" beyond the hole.
8. Remove the wedge and adjust the top clamp so the spring is compressed about 3/4" inch. Tape should be hanging straight. Tighten all nuts and bolts.

SELECTOR HEAD INSTALLATION

1. It is much easier to install the selector head at tape installation step 5, as you don't have to remove and reinstall the guides. If the tape is already installed, remove the upper and lower guides from either side of the unit by loosening the screws on each guide.
2. Install the selector head onto the tape with the 15-pin connector facing up, and then reinstall the guides removed in step one. Check that the unit rides freely in the tape.
3. Fabricate brackets if required to attach the unit to the car with the heim joint as shown in FIG. 2.
4. Route the 15-pin communication cable to the interface board and secure as required. Plug the communication cable into the interface board.

MAGNET ORIENTATION

CENTER LANE: Leveling & Door Zone, White side facing car on all floors, 11” magnet

LEFT LANE: P1 (Tan facing car) and P3 (White facing car)

RIGHT LANE: P2 (Tan facing car) and P4 (White facing car)

MAGNET INSTALLATION

1. Put controller into “TEMPORARY RUN MODE”
2. Position the car at floor level. Mark the steel tape at the top of the selector head.
3. Move the car below floor level 2-3’
4. Mark the steel tape 2 ¼” below the original mark
5. Position the top of the Door Zone magnet in the center of the tape at the height of the lower mark, white side facing the car (do not remove tan side adhesive backing at this time).
6. Move car up and verify car position with controller signals. Move Door Zone magnet as necessary to achieve floor level.
7. Mark the tape at the top and bottom of each Door Zone magnet.
8. Repeat steps 2-7 for each landing
9. Attach the Positioning magnets. Refer to the appropriate diagram for the control system you are installing.
10. Verify the running speed and the leveling speed of the car. Adjust the slowdown control (usually called transition for hydraulics and decel for electric) per the manufacturer's recommendation. If the car overshoots the floor with maximum slowdown, trim ¼” off the top of the Zone magnet.
11. Check operation in both directions at every landing. Adjust magnets as needed. When operation is satisfactory, mark the location of the magnets with a marker or scribe, remove the magnets, remove the backing and reapply the magnets in the same place. Marking the magnets will help in the future if a magnet should ever fall off.

SELECTOR INTERFACE PCB

1. Connect travel cables and power to the PCB.
2. Set the slide switch as follows:
 - a. 4M2XX Controller: LOW / MHTAL (L)
 - b. 6M2XX Controller: HIGH / EMTAL6 (H)

Note: If the switch is set incorrectly, the selector inputs to the controller will be opposite.

Your installation is now complete!

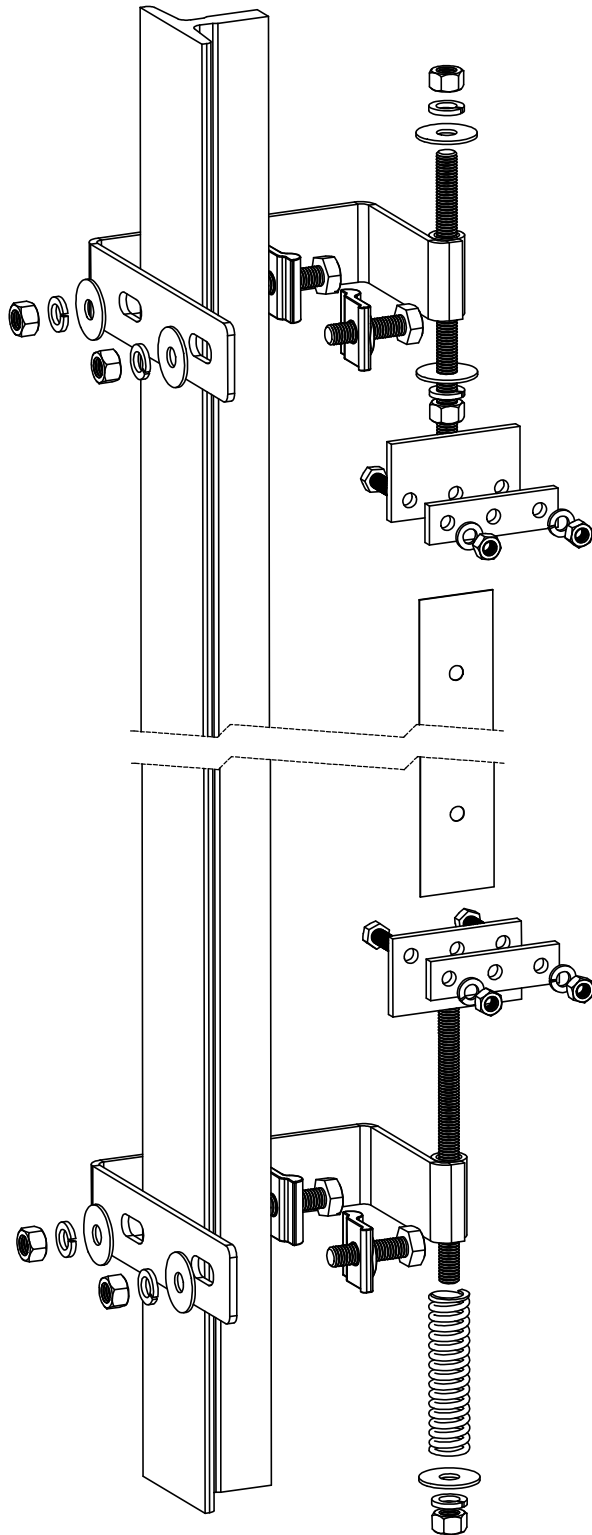

UPPER CLAMP ASSEMBLY
FIG. 1A

LOWER CLAMP ASSEMBLY
FIG. 1B

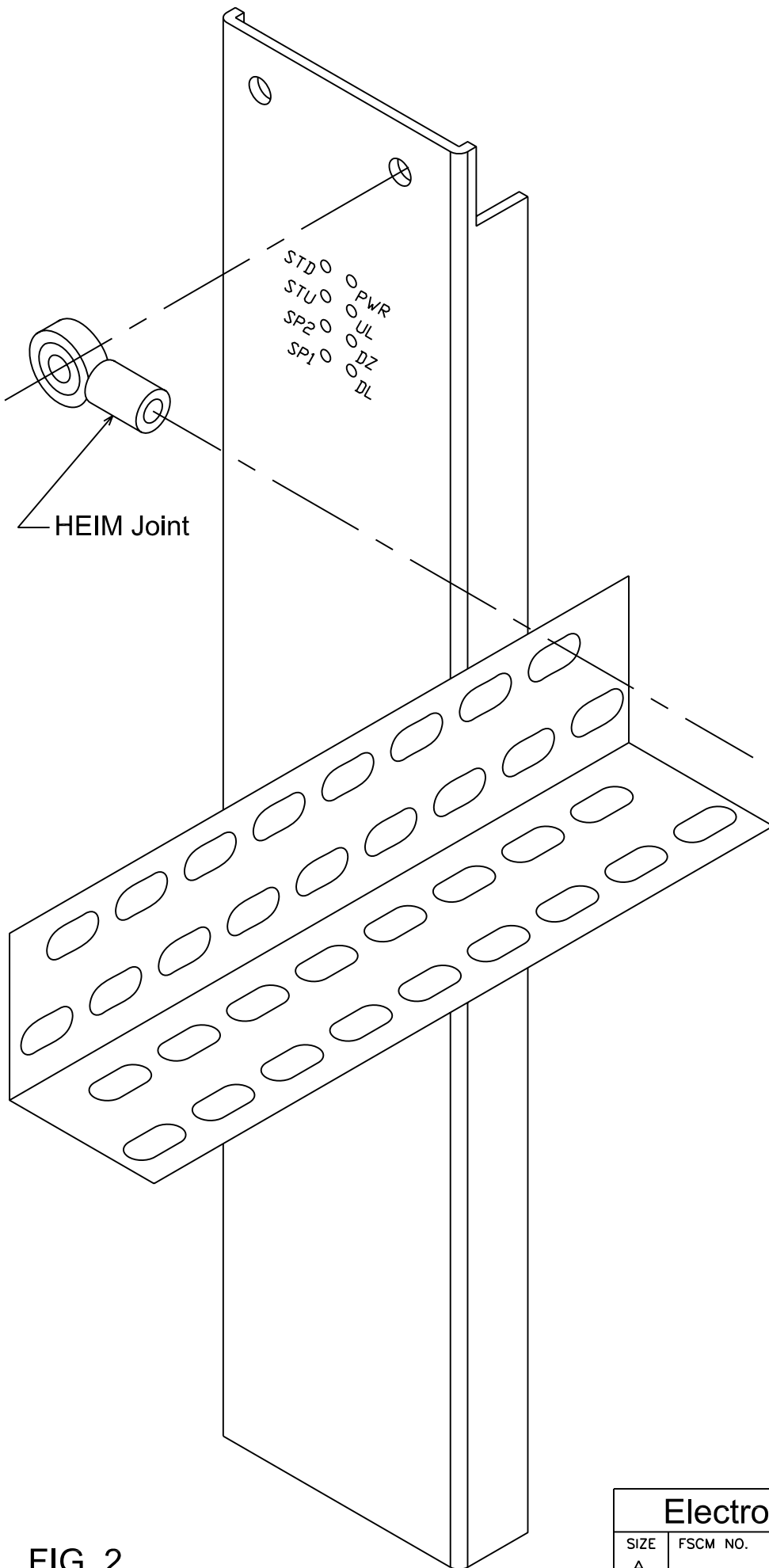
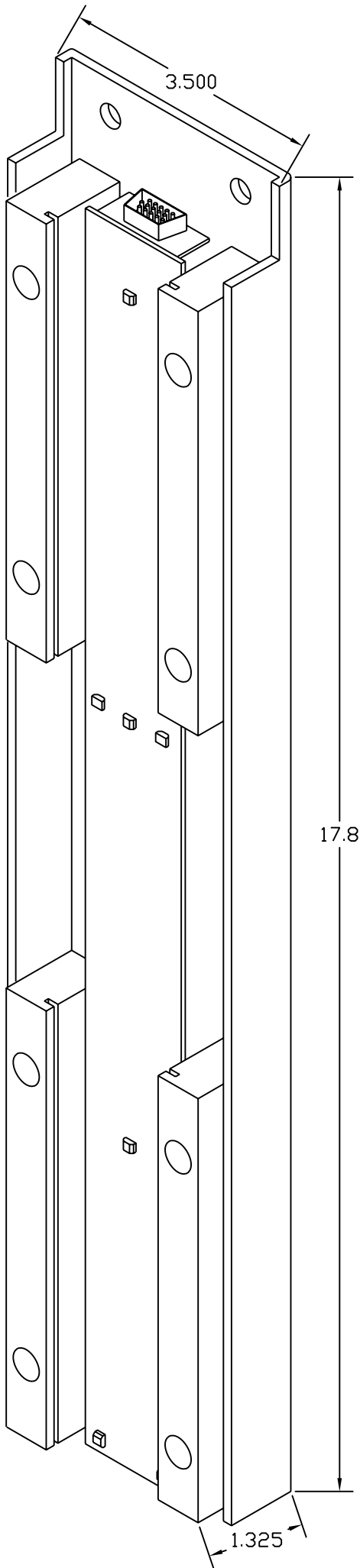
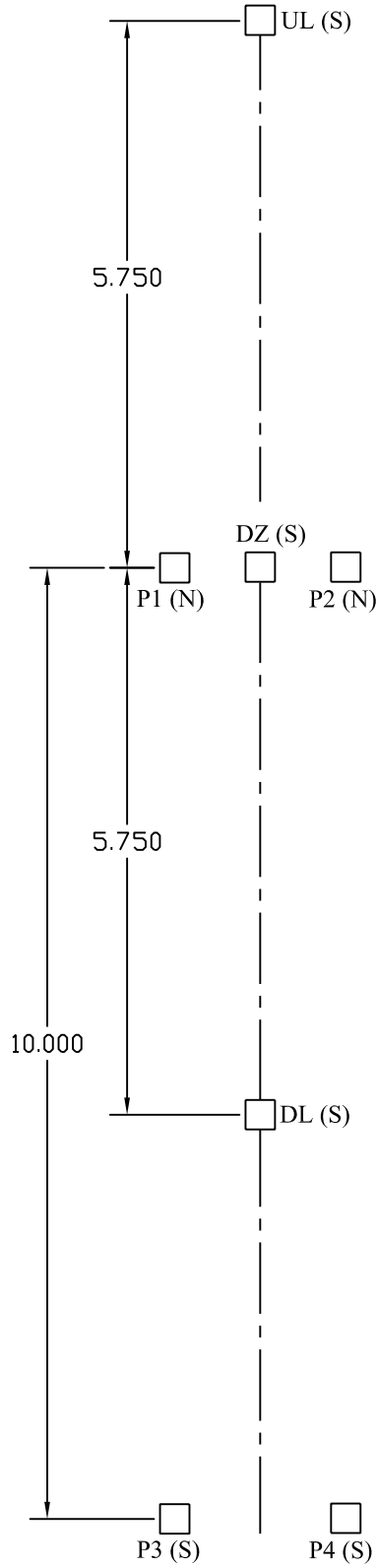

FIG. 2

Electro Mech Industries, Inc.			
SIZE A	FSCM NO.	DWG NO. SELMTG KIT	REV
SCALE: None			SHEET



SENSOR SPACING



Electro Mech Industries, Inc.

SIZE A	FSCM NO.	DWG NO. SEL2	REV 1
SCALE: None		SHEET	

4M2xx Selector Logic Requirements

The 4M2 Controllers require seven selector inputs for proper operation:

LU = Level Up	P1 = Verifies Car is at Position 1
LD = Level Down	P2 = Verifies Car is at Position 2
DZ = Door Zone	P3 = Verifies Car is at Position 3
	P4 = Verifies Car is at Position 4

The inputs are 24VDC active low; meaning that 0VDC (REF) must be present at the appropriate controller terminal to activate the input.

Up / Down Travel Logic Sequence:

- When a call is registered, a directional output (UP or DN) along with outputs “RP” and “HS” will be activated.
- Each time a Leveling signal (**UL**: Running UP & **DL**: Running DOWN) is activated the Microprocessor will increment or decrement one level. This value must match the “Px” input from the selector otherwise a “SELECTOR FAULT” will occur.
- When the Microprocessor increments or decrements to the destination landing, the “HS” output will deactivate and the car will decelerate to leveling speed.
- To stop the car after it is running in leveling speed, **UL** or **DL** turns off while **DZ** remains on. The directional output “UP” or “DN” is deactivated then after 3 seconds “RP” output is deactivated.
- Refer to fig. S1 for the required selector output sequence.

Releveling (Hydro Only)

After the car has stopped at floor level in response to a call, the car will re-level up when **UL** and **DZ** are on together, and will stop when **LU** is off. The car will re-level down if **DL** and **DZ** are on together, and will stop when **DL** is off. Releveling is deactivated for single speed and VVVF winding drums.

Positive Encoding:

The 4M2 Controllers achieve positive encoding via four independent positioning magnets. Door Lock outputs will be activated only when the positioning magnet matches the internal counter.

Short Floors:

- The “HS” output is not activated when running between the two short floors
- The minimum vertical gap between the two adjacent short floor zone magnets is 1.5”.
- The minimum travel distance with our selector is 12.5 inches when operating in Automatic Push button mode.
- Contact the factory for the required selector output sequence.

G.A.L. Interlocks with a fixed cam:

- The hoistway door lock (HDL) input is bridged by the normally open contacts of the “DZ” and “Q” relays.
- Relay “Q” is activated only when the Microprocessor has a position (Px) input from the selector.
- Relay “DZ” is activated only when the elevator is in the door zone (DZ input from the selector).
- Therefore the door is allowed to be un-locked (by the fixed cam) only when a position output from the selector (Px) is active.
- If the position signal (Px) is removed and the door is not locked, the call will be dropped and the car will stop.
 - If the car comes to rest within the door zone, it will re-level to that floor.

6M2Hx Selector Logic Requirements

The 6M2 Controllers require six selector inputs for proper operation:

LU = Level Up	P1 = Binary value 1
LD = Level Down	P2 = Binary value 2
DZ = Door Zone	P3 = Binary value 4

The inputs are 24VDC active HIGH; meaning that 24vdc must be present at the appropriate controller terminal to activate the input.

Up / Down Travel Logic Sequence:

- When a call is registered, a directional output (UP or DN) along with outputs “RP” and “HS” will be activated.
- Each time a Leveling signal (**UL**: Running UP & **DL**: Running DOWN) is activated the Microprocessor will increment or decrement one level. This value must match the binary values of the “Px” input(s) from the selector otherwise a “SELECTOR FAULT” will occur.
- When the Microprocessor increments or decrements to the destination landing, the “HS” output will deactivate and the car will decelerate to leveling speed.
- To stop the car after it is running in leveling speed, **UL** or **DL** turns off while **DZ** remains on. The directional output “UP” or “DN” is deactivated then after 3 seconds “RP” output is deactivated.
- Refer to fig. S3 for the required selector output sequence.

Releveling (Hydro Only)

After the car has stopped at floor level in response to a call, the car will re-level up when **UL** and **DZ** are on together, and will stop when **LU** is off. The car will re-level down if **DL** and **DZ** are on together, and will stop when **DL** is off. Releveling is deactivated for single speed and VVVF winding drums.

Positive Encoding:

The 6M2 Controllers achieve positive encoding via three independent positioning magnets. The positioning magnets are configured to produce a binary count for each floor. Door Lock outputs will be activated only when the positioning magnet(s) matches the internal counter.

Short Floors:

- The “HS” output is not activated when running between the two short floors
- The minimum vertical gap between the two adjacent short floor zone magnets is 2”.
- The minimum travel distance with our selector is 13 inches when operating in Automatic Push button mode.
- Contact the factory for the required selector output sequence.

G.A.L. Interlocks with a retiring cam:

- Retiring cam operation can supported by the 6M2 controllers.
- Contact the factory for the required interface schematics

G.A.L. Interlocks with a fixed cam:

- Fix cam operation is NOT supported by the 6M2 controllers.

Required Selector Signals 4M2 Controller Series

RUNNING UP							
CAR LOCATION	DZ	UL	DL	P1	P2	P3	P4
@ FL 1	X			X			
	X		X	X			
	X		X	O			
	O		X				
ALL OFF			O				
		X					
	X	X					
	X	X			X		
@ FL 2	X	O			X		
	X		X		X		
	X		X		O		
	O		X				
ALL OFF			O				
		X					
	X	X					
	X	X				X	
@ FL 3	X	O				X	
	X		X			X	
	X		X			O	
	O		X				
ALL OFF			O				
		X					
	X	X					
	X	X					X
@ FL 4	X	O					X

X= LED ON
O= LED HAS TURNED OFF

RUNNING DOWN							
CAR LOCATION	DZ	UL	DL	P1	P2	P3	P4
@ FL 4	X						X
	X	X					X
	X	X					O
	O	X					
ALL OFF		O					
			X				
	X		X				
	X		X			X	
@ FL 3	X		O			X	
	X	X				X	
	X	X				O	
	O	X					
ALL OFF		O					
			X				
	X		X				
	X		X		X		
@ FL 2	X		O		X		
	X	X			X		
	X	X			O		
	O	X					
ALL OFF		O					
			X				
	X		X				
	X		X	X			
@ FL 1	X		O	X			

X= LED ON
O= LED HAS TURNED OFF

**Required Selector Signals
6M2 Controller Series**

RUNNING UP						
CAR LOCATION	DZ	UL	DL	P1	P2	P3
@ FL 1	X			X		
	X		X	X		
	X		X	O		
	O		X			
ALL OFF			O			
		X				
	X	X				
	X	X			X	
@ FL 2	X	O			X	
	X		X		X	
	X		X		O	
	O		X			
ALL OFF			O			
		X				
	X	X				
	X	X		X	X	
@ FL 3	X	O		X	X	
	X		X	X	X	
	X		X	O	O	
	O		X			
ALL OFF			O			
		X				
	X	X				
	X	X				X
@ FL 4	X	O				X
	X		X			X
	X		X			O
	O		X			
ALL OFF			O			
		X				
	X	X				
	X	X		X		X
@ FL 5	X	O		X		X
	X		X	X		X
	X		X	O		O
	O		X			
ALL OFF			O			
		X				
	X	X				
	X	X			X	X
@ FL 6	X	O			X	X

X= LED ON
O= LED HAS TURNED OFF

RUNNING DOWN						
CAR LOCATION	DZ	UL	DL	P1	P2	P3
@ FL 6	X				X	X
	X	X			X	X
	X	X			O	O
	O	X				
ALL OFF		O				
			X			
	X		X			
	X		X	X		X
@ FL 5	X		O	X		X
	X	X		X		X
	X	X		O		O
	O	X				
ALL OFF		O				
			X			
	X		X			
	X		X			X
@ FL 4	X		O			X
	X	X				X
	X	X				O
	O	X				
ALL OFF		O				
			X			
	X		X			
	X		X	X	X	
@ FL 3	X		O	X	X	
	X	X		X	X	
	X	X		O	O	
	O	X				
ALL OFF		O				
			X			
	X		X			
	X		X		X	
@ FL 2	X		O		X	
	X	X			X	
	X	X			O	
	O	X				
ALL OFF		O				
			X			
	X		X			
	X		X	X		
@ FL 1	X		O	X		

X= LED ON
O= LED HAS TURNED OFF

Procedure to: Minimize UP Re-Leveling condition on 4M2 & 6M2

Overview: The elevator should not re-level when a person steps into the cab.

1. Adjust valve to achieve your preferred ride quality
(i.e. UP / DN acceleration, deceleration, leveling speeds and DN full speed)
2. Place Selector magnets in their approximate vertical location(s) on the selector tape.
3. Run car in normal mode in both directions
 - a. Verify that car does not overshoot the floor. If this occurs further valve adjustment(s) is necessary
4. Move selector magnets to their final vertical position.
 - a. Scribe a line on the selector tape at the bottom of the Zone magnet (11") at all floors.
 - b. Verify that car stops at floor level at all floors in both directions.
Note: At this point there is virtually no "dead zone". The slightest rope stretch due to loading or cooling of the oil will induce a re-level condition.
5. Cut $\frac{3}{4}$ " off of the TOP of the Zone magnet (11") at every floor.
Note: The car will now stop below the floor when running UP.
6. Using the P-Tool, go to programming parameter "UP STOP DELAY"
 - a. Set this parameter to 10
 - b. Cause a re-level by opening manual lowering on valve
 - c. After relevel is complete, Increment this parameter by 10
 - d. Repeat steps "b" & "c" until selector input "DL" comes on and the car levels back down to the floor, then proceed to step 6.e.
 - e. Decrease this parameter by 5.
 - f. Cause a re-level by opening manual lowering on valve, "DL" should not activate.
Note: If DL still activates, decrease this parameter by 5.